

ENG

COMBIFLEX

Pneumatic brake

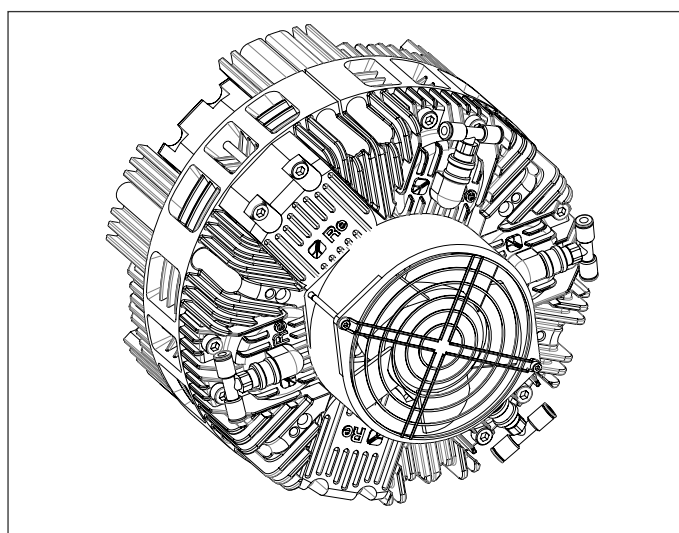

USER'S MANUAL



Contents

Warnings	1
Description	1
Mounting the Combiflex brake on your machine	2
Replacing the pads	3
Replacing the turbin disc	4
CX.200 brake	5
Assembly - CX.200.....	5
Turbine disc - CX.200	5
CX.250 brake	6
Assembly - CX.250.....	6
Turbine disc - CX.250	7
Cover - CX.250.....	7
6 poles female tap linkage diagram - CX.250.....	8
CX.251 brake	9
Assembly - CX.251.....	9
Turbine disc - CX.251	10
Cover - CX.251.....	10
Electro pneumatic box - CX.251	11
6 poles connector linkage diagram - CX.251	11
CX.300 brake	12
Assembly - CX.300.....	12
Turbine disc - CX.300	13
Electro pneumatic box - CX.300	13
6 poles connector linkage diagram - CX.300	14
CX.400 brake	15
Assembly - CX.400.....	15
Turbine disc - CX.400	16
Fans connection diagrams - CX.400	16
CX.500 brake	18
Assembly - CX.500.....	18
Turbine disc - CX.500	19
Fans connection diagrams - CX.500	19
Fans for CX brakes - technical data	21
CX half caliper - internal side	22
CX half caliper - external side	22
Reduced calipers	23
Pads	24
Guarantee	25

Warnings

The present manual is for device fitters and operators. It provides indications on the intended use of the device, technical specifications and instructions for installation, adjustment and use.

This manual is an integral part of the device and must be kept until the device is decommissioned. It reflects the technical state of the device at the time of its sale.

The plant builder may include the present manual in the documentation for plant use.

Re S.p.A. reserves the right to update its production and/or manuals without updating products already sold and previous manuals.

Since the device forms part of a plant, the plant builder is responsible for ensuring that all parts comply with the laws in force in the country in which it is installed.

The device must be fitted and adjusted by qualified technical personnel.

It may be moved manually.

Description

The COMBIFLEX brake has been designed to be a compact, inexpensive and high performance brake. This ensures that it will completely satisfy the requested application demands.

This brake's simple, low maintenance design gives it the advantage of being easily disassembled for periodical maintenance.

To maintain the brake always in optimal functioning conditions it is recommended:

- **verify the correct application of the brake**
- **control the pads wear and replace them when necessary** (see page 3 *Replacing the pads*)
- **control the turbine disc and replace it when necessary** (see page 4 *Replacing the turbine disc*)
- **verify that the disc surfaces are sufficiently smooth, if not turn both of the disc faces being careful to maintain the thickness suitable to use** (see page 4 *Replacing the turbine disc*)
- Supply the calipers using **compressed “dry” air, without any kind of lubricating**
- **The air pressure used to supply the calipers, must not be more than 6bar.** If a higher air pressure is necessary for particular applications, special calipers are available (on customers requests): these are interchangeable to the standard calipers, and allow to supply the brake until 10bar.

Mounting the Combiflex brake on your machine

A

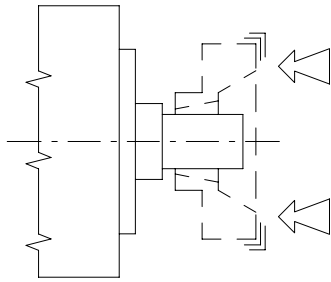

Mount the brake disc on the shaft without locking it.

B

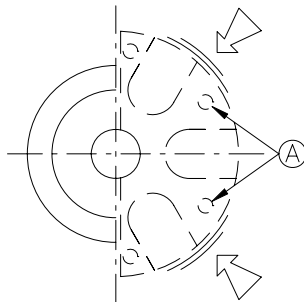

Assemble the half-housing, attaching it to the machine flange at 4 points labelled "A" in the diagram. Tighten the 4 screws with torque of 2,2 DaNm.

C

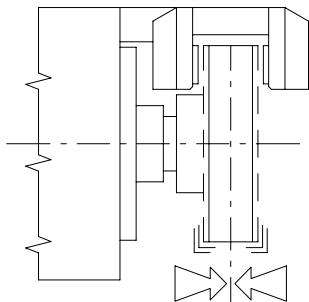

Center the disc between the two lining pads using a feeler, then lock the disc. Rotate manually the disc and verify that the deviation of the disc's parallelism in respect of the flange is $\pm 0,1$ mm.

D

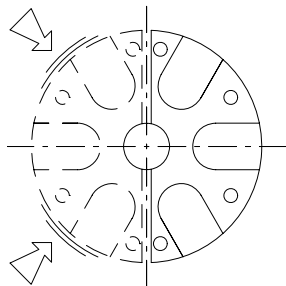

Assemble the second half housing as described above in point "B".

E

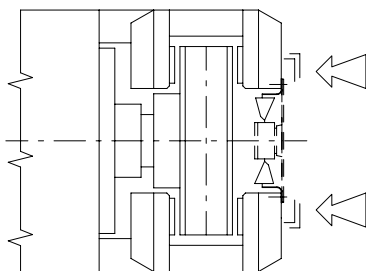

Attach the fan (if present) using the 4 screws which are mounted on the fan.

Attention! When you mount the fan, verify that **the arrow on it is pointing toward the brake** (the flow of the air is going from outside into the brake)

If the fan is provided with the cover, attach the cover to the brake, using the appropriate fixing screws

Replacing the pads

The R15 brake pads (code 01A67016) are produced with material without asbestos and when used correctly will last between 7500 and 10000 hours. However the pad's lifetime can undergo remarkable variations due to the high exercise temperatures, and it is useful to verify the correct application of the brake.

Moreover, we recommend that you inspect the thickness of the pads: **the brake pads should be replaced if the thickness reaches 5mm.**



Attention! Sometimes the pad could wear not uniformly; in this case measure the higher thickness: **replace the pad when the higher thickness reaches 6,5mm.**

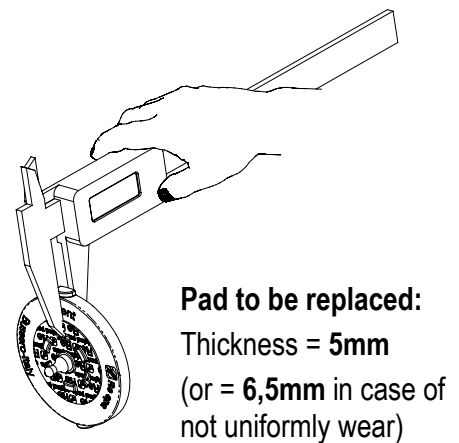
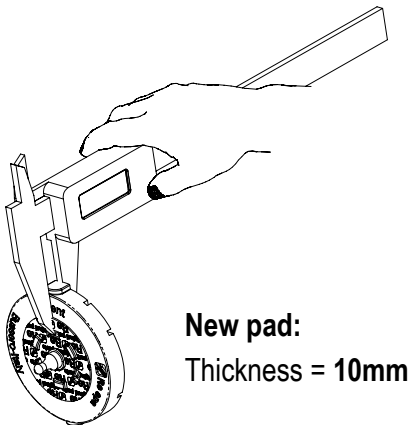

Replacing procedure:

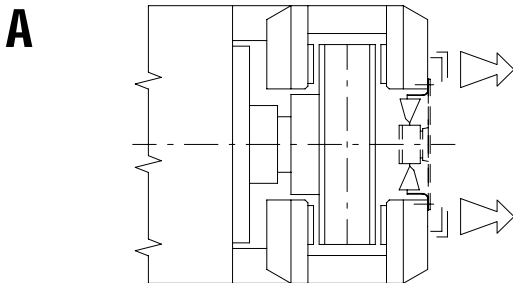

Remove the fan, if present, or the cover (if the fan is provided with the cover).

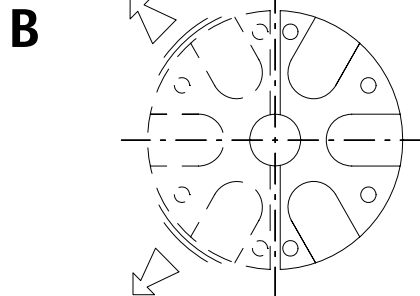

Remove the first half housing, and then the second half.

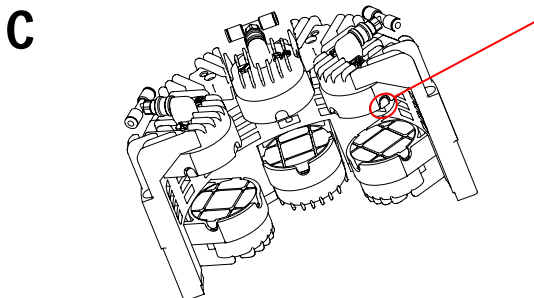

Dismount the pads fixed to the piston with a retaining spring (code 4258910) using a screwdriver. Replace it inserting new pads and press them until they are seated.

D

Re-assemble both of the half-housings, then attach the fan or the cover, if present, following the procedure on page 2 (*Mounting the Combiflex brake on your machine*).

Replacing the turbin disc

The cast iron turbine disc does not require particular maintenance procedures.

Anyway, we recommend that you inspect the thickness of the disc (this operation is easy to do during the pads replacing, when the brake is dismantled): **the disc should be replaced if the thickness reaches 46mm (in CX200, CX250, CX251 and CX300 brakes) or 51mm (in CX400 and CX500 brakes).**

If the disc surfaces are not sufficiently smooth, turn both of the disc faces being careful the thickness does not reach the minimum values indicated above.

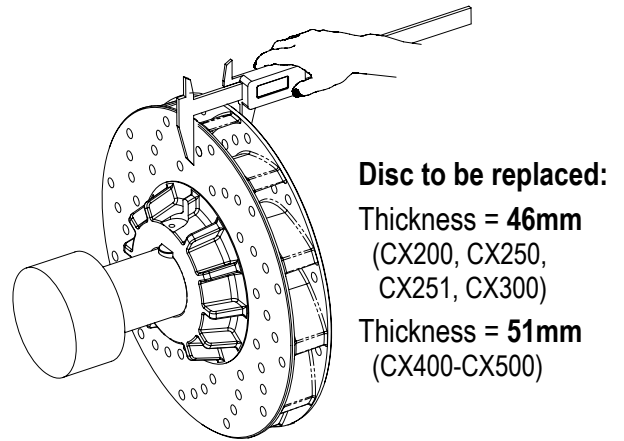
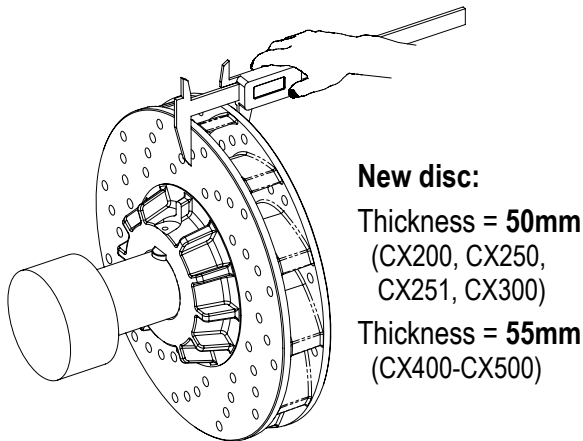

Replacing procedure:

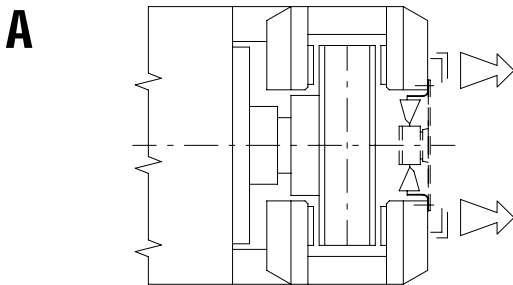

Remove the fan, if present, or the cover (if the fan is provided with the cover).

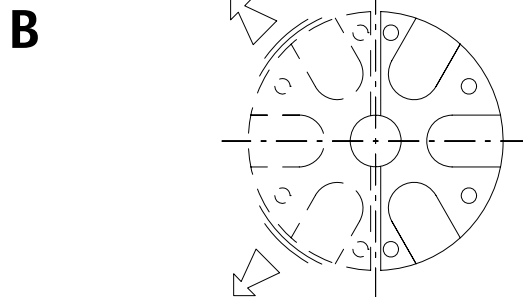

Remove the first half housing, and then the second half.

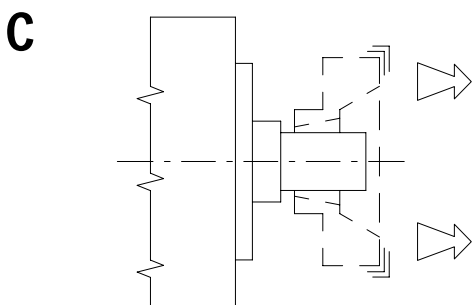

Dismount the brake disc from the shaft.

D

Mount the new disc, both of the half-housings, then attach the fan or the cover, if present, following the procedure on page 2 (*Mounting the Combiflex brake on your machine*).

CX.200 brake

Assembly - CX.200

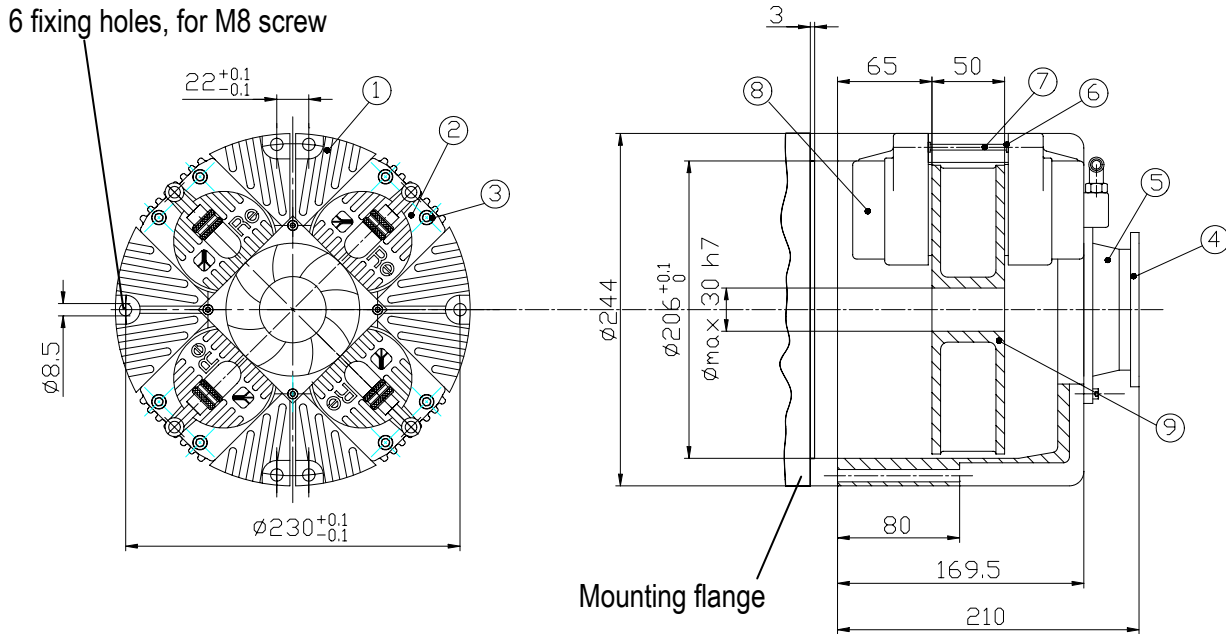

POS.	Q.TY	CODE	DESCRIPTION
1	2	4200213	CX200 HALF HOUSING
2	X	4253100	OUTSIDE CALIPER
3	8	10001094	SCREW 8x100 UNI 5931
4	1	01A09003	CX200 HALF HOUSING PROTECTION GRID
5	1	80000005	CX200 FAN 3606 115V 50/60HZ
5	1	80000008	CX200 FAN 3650 220V 50/60HZ
5	1	80000014	CX200 FAN 24Vdc COD.3314
6	8	20000416	O-RING 6BIS VITON
7	4	4259110	CX200/300 AIR TUBE
8	X	4253200	INSIDE CALIPER
9	1	4204715	BRAKE FLAT DISC

Turbine disc - CX.200

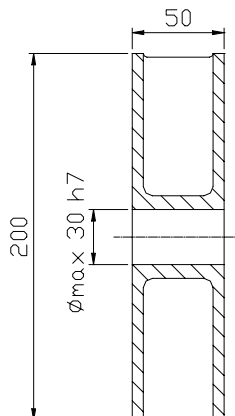

CX.250 brake

Assembly - CX.250

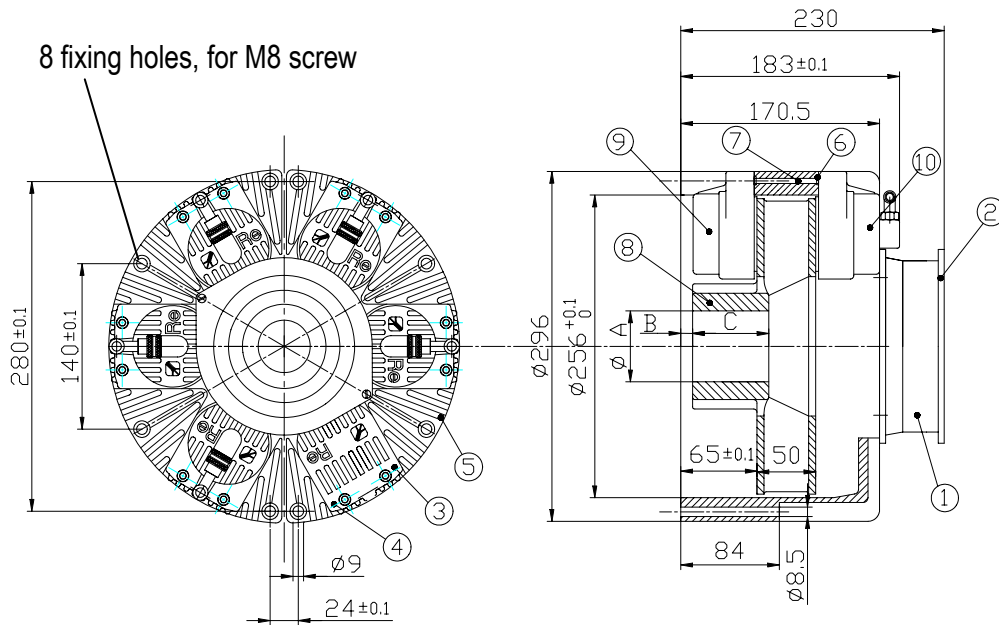

Dimension ØA subject to change: Min. 35mm - Max. 70mm with key
With taper lock, max shaft Ø 45mm

Dimension B: 10mm with long hub - 35mm with short hub

Dimension C: 65mm with long hub - 40mm with short hub

POS.	Q.TY	CODE	DESCRIPTION
1	1	80000024	FAN DIAM.150 24Vdc
1	1	80000002	FAN SET 7000-V115.50/60HZ
1	1	80000001	FAN SET 7000-V220.50/60HZ
2	1	42501001	CX 250/300 FAN GRILLE
3	X	4253310	INSIDE CARTER
4	X	4253911	OUTSIDE CARTER
5	2	4250212	HALF HOUSING
6	12	20000416	O-RING 6BIS VITON
7	6	4259110	CX 200/300 AIR TUBE
8	1	4254718	MACHINED BRAKE DISC STD
9	X	4253200	INSIDE CALIPER
10	X	4253100	OUTSIDE CALIPER

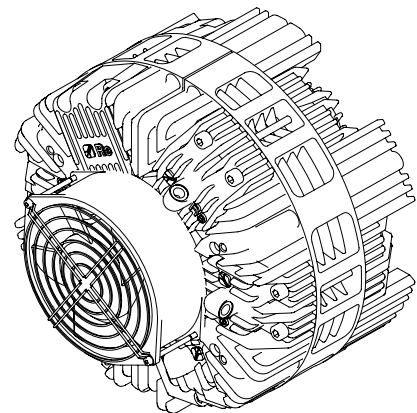

Turbine disc - CX.250

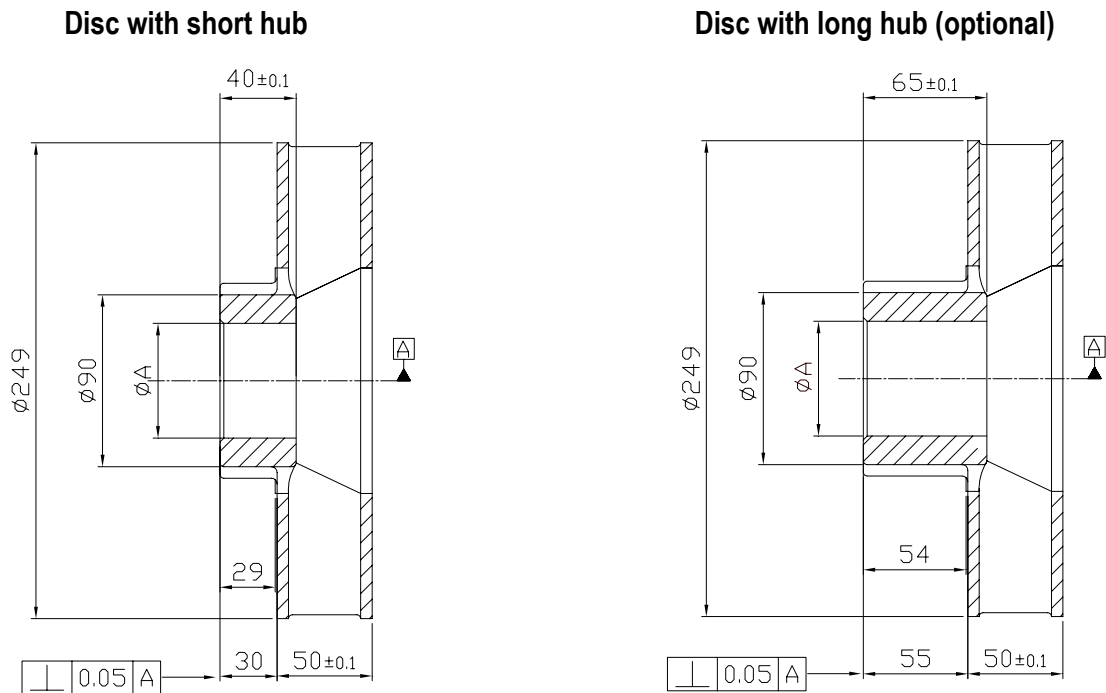

Dimension ØA subject to change on the basis of the customers requests: Min. 35mm - Max. 70mm with key
 With taper lock, max shaft Ø 45mm

Cover - CX.250

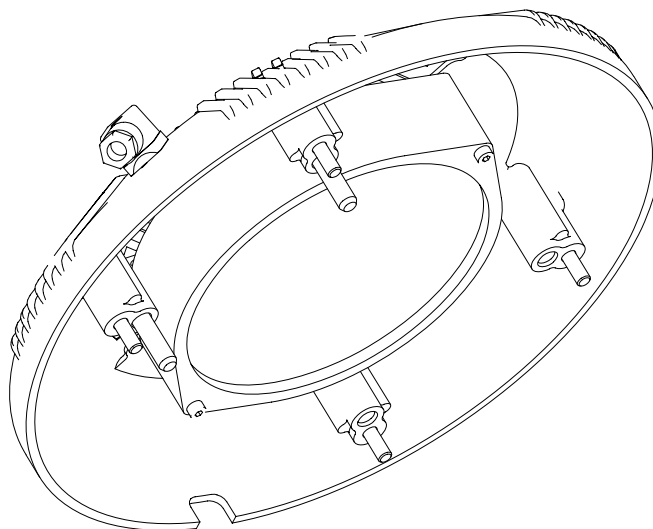

CODE	DESCRIPTION
01A09016	CX251 COVER 24V 6 POLES CONNECTOR
01A09026	CX251 COVER 115V 6 POLES CONNECTOR
01A09027	CX251 COVER 220V 6 POLES CONNECTOR

6 poles female tap linkage diagram - CX.250

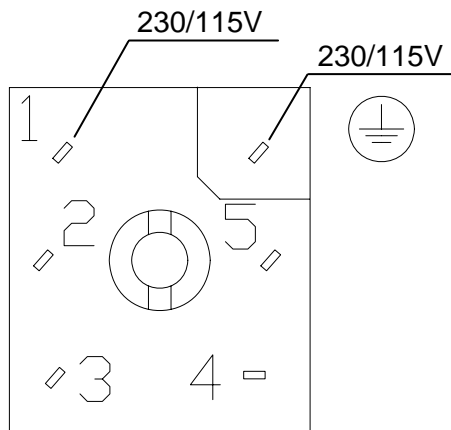
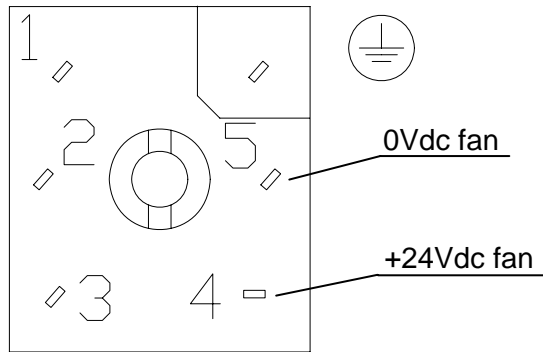

CX.251 brake

Assembly - CX.251

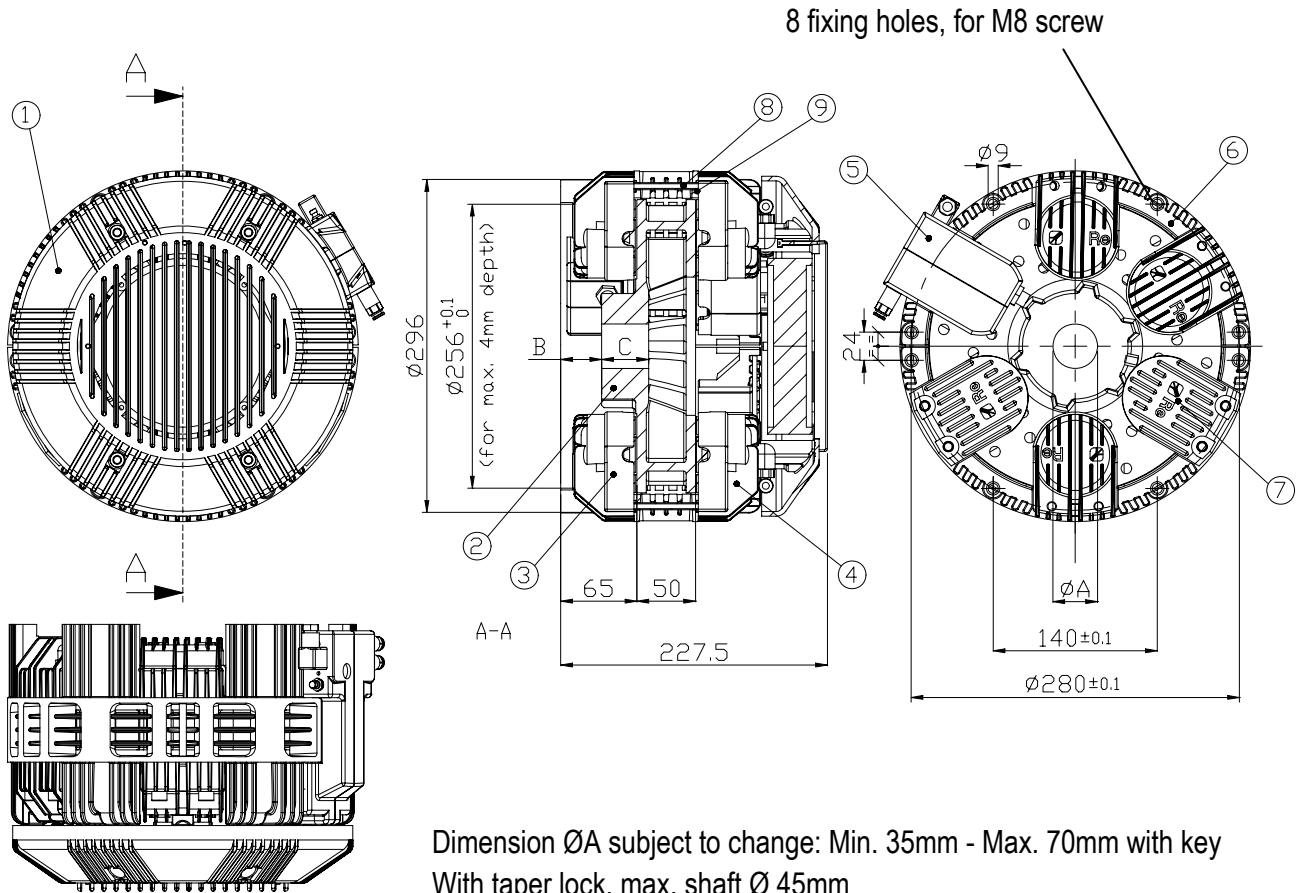

Dimension ϕA subject to change: Min. 35mm - Max. 70mm with key
 With taper lock, max. shaft ϕ 45mm

Dimension B: 10mm with long hub - 35mm with short hub

Dimension C: 65mm with long hub - 40mm with short hub

POS.	Q.TY	CODE	DESCRIPTION
1	1	01A09009	COVER 24V
2	1	4254716	BRAKE DISC
3	X	4253200	INSIDE CALIPER
4	X	4253100	OUTSIDE CALIPER
5	1	01A44020	ELECTRO PNEUMATIC BOX
6	2	4250212	HALF HOUSING
7	X	4253911	OUTSIDE CARTER
7	X	4253310	INSIDE CARTER
8	6	4259110	CX250 AIR TUBE
9	12	20000416	O-RING 6BIS VITON

- The drawing shows a 3 calipers brake -

Turbine disc - CX.251

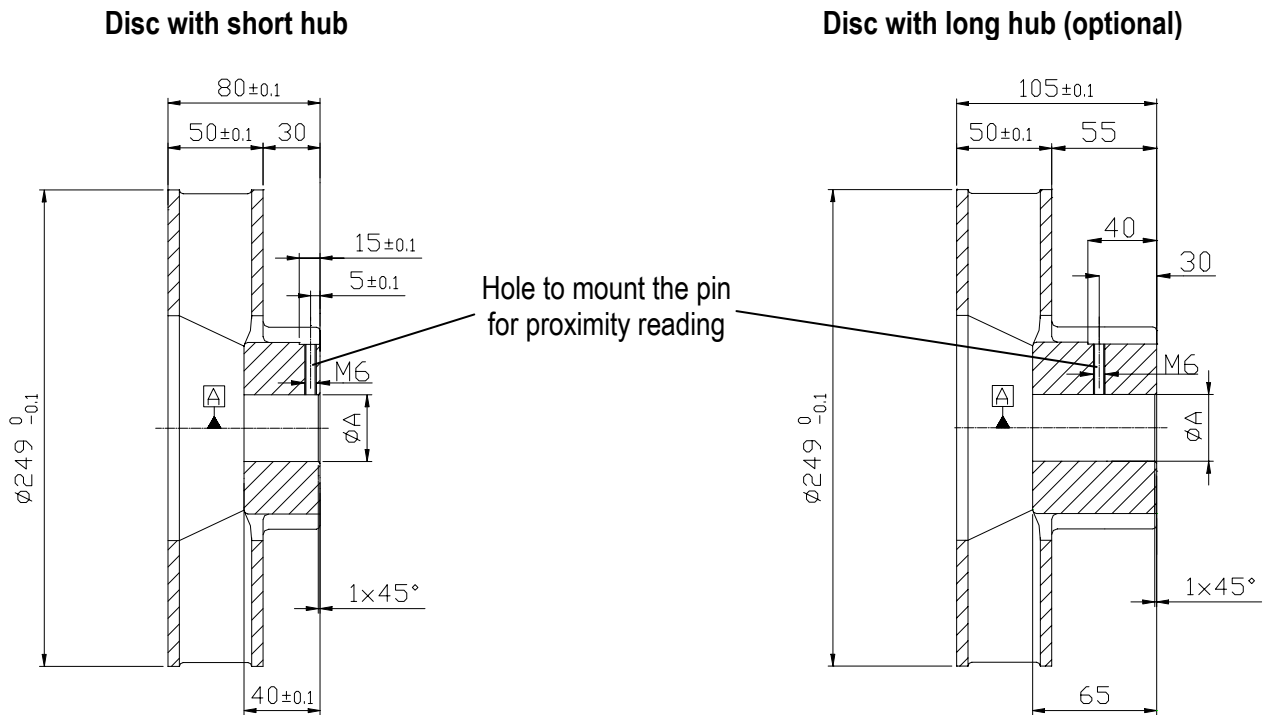

Dimension $\varnothing A$ subject to change on the basis of customers requests: Min. 35mm - Max. 70mm with key
 With taper lock, max shaft \varnothing 45mm

Cover - CX.251

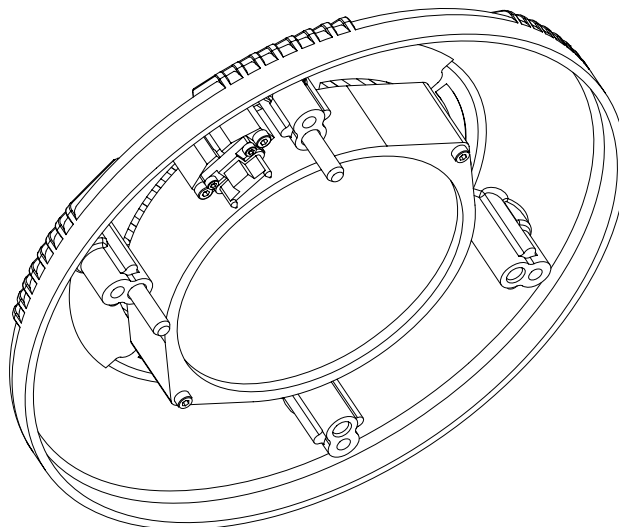

CODE	DESCRIPTION
01A09009	CX251 COVER 24V INSIDE CONNECTOR

Electro pneumatic box - CX.251

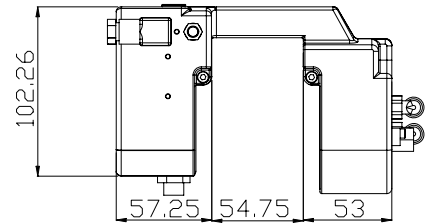
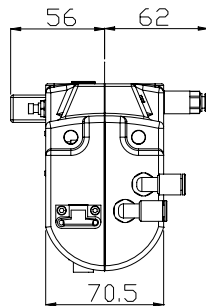

Note: the electro-pneumatic box is provided with 2 air courses; they are distinguished by different colours of inputs and outputs; implement the pneumatic connections by using input and output of the same colour.

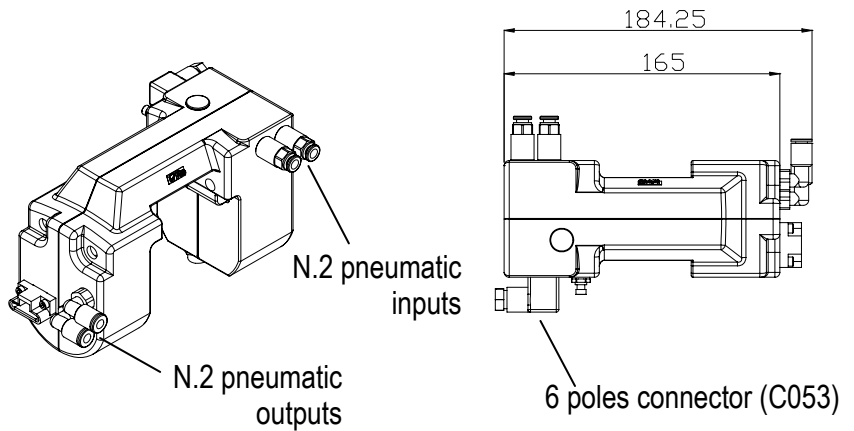

6 poles connector linkage diagram - CX.251

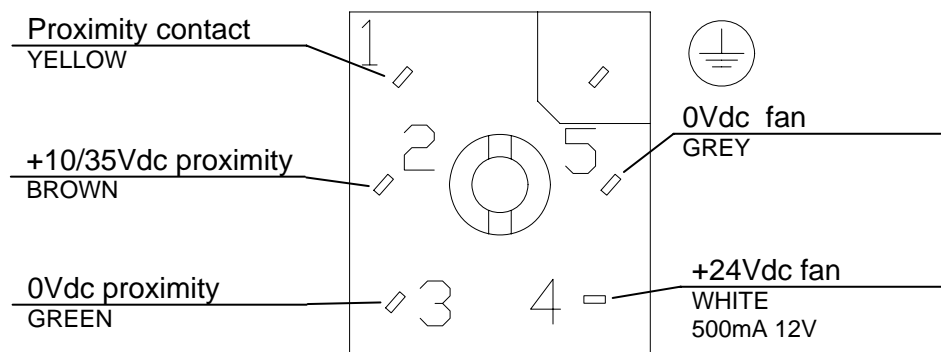

CX.300 brake

Assembly - CX.300

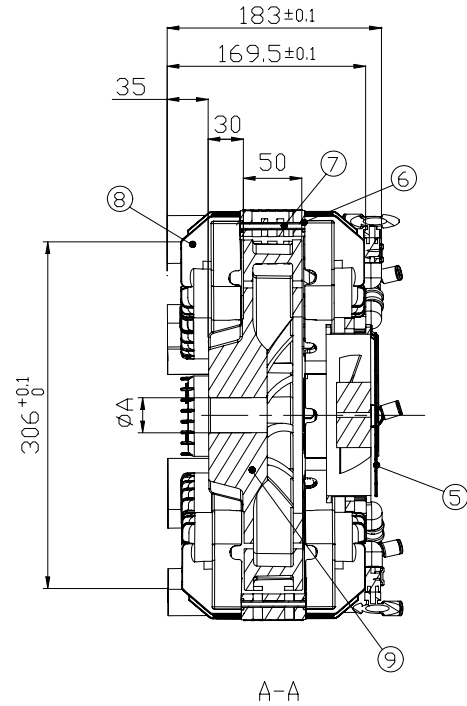
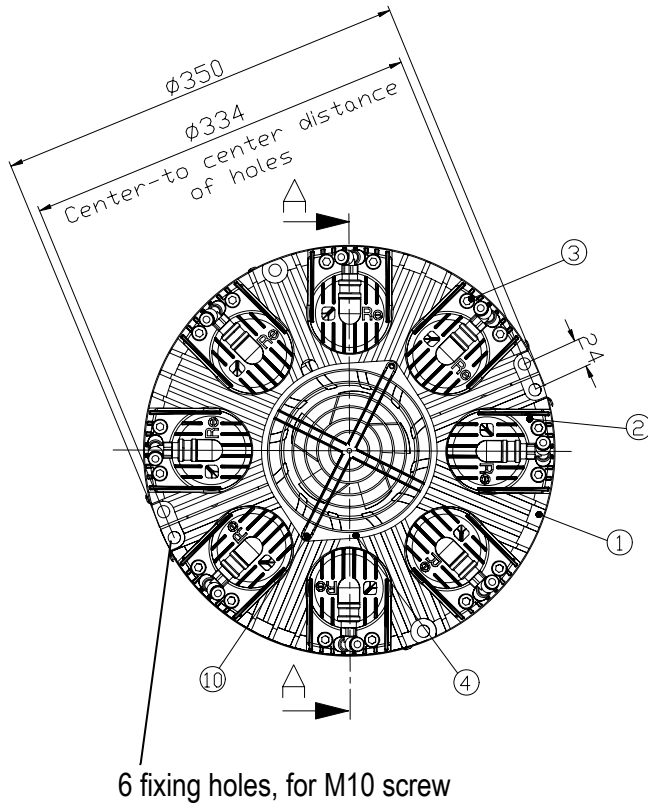

Dimension ØA subject to change: Min. 35mm - Max. 85mm with key
 With taper lock, max. shaft Ø 65mm

POS.	Q.TY	CODE	DESCRIPTION
1	2	4300210	CX300 HALF HOUSING
2	X	4253100	OUTSIDE CALIPER
3	16	10001094	SCREW 8x100 UNI 5931
4	1	80000002	FAN SET 7000 V115.50/60HZ
4	1	80000001	FAN SET 7000 V220.50/60HZ
4	1	43079003	CX300 FAN V24
5	1	42501001	CX250/300 FAN GRILLE
6	16	20000416	O-RING 6BIS VITON
7	8	4259110	CX200/300 AIR TUBE
8	X	4253200	INSIDE CALIPER
9	1	4304712	MACHINED BRAKE DISC
10	2	10001025	SCREW 4x35 UNI 5931

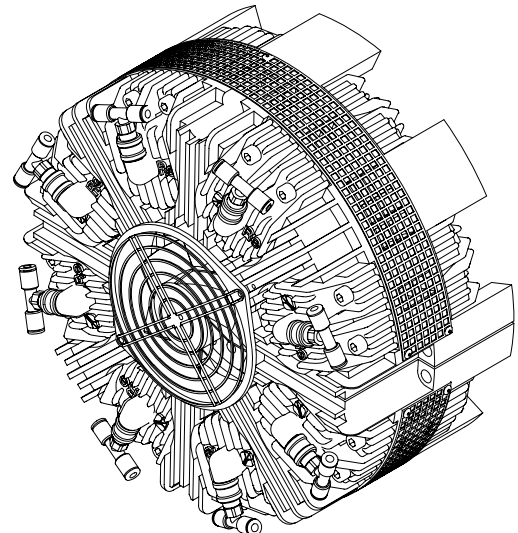

Turbine disc - CX.300

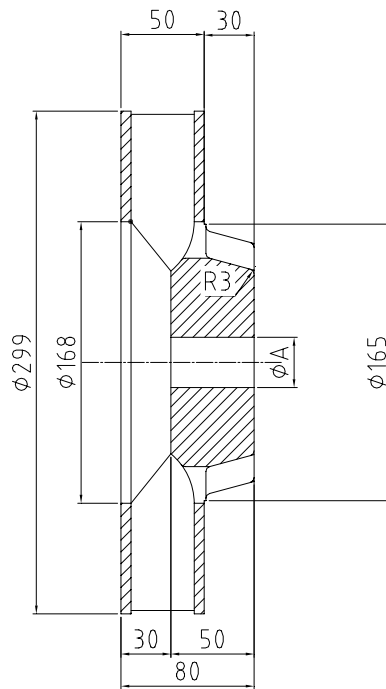

Dimension ØA subject to change on the basis of the customers requests: Min. 35mm - Max. 85mm with key
 With taper lock, max. shaft Ø 65mm

Electro pneumatic box - CX.300

Note: the electro-pneumatic box is provided with 2 air courses; they are distinguished by different colours of inputs and outputs; implement the pneumatic connections by using input and output of the same colour.

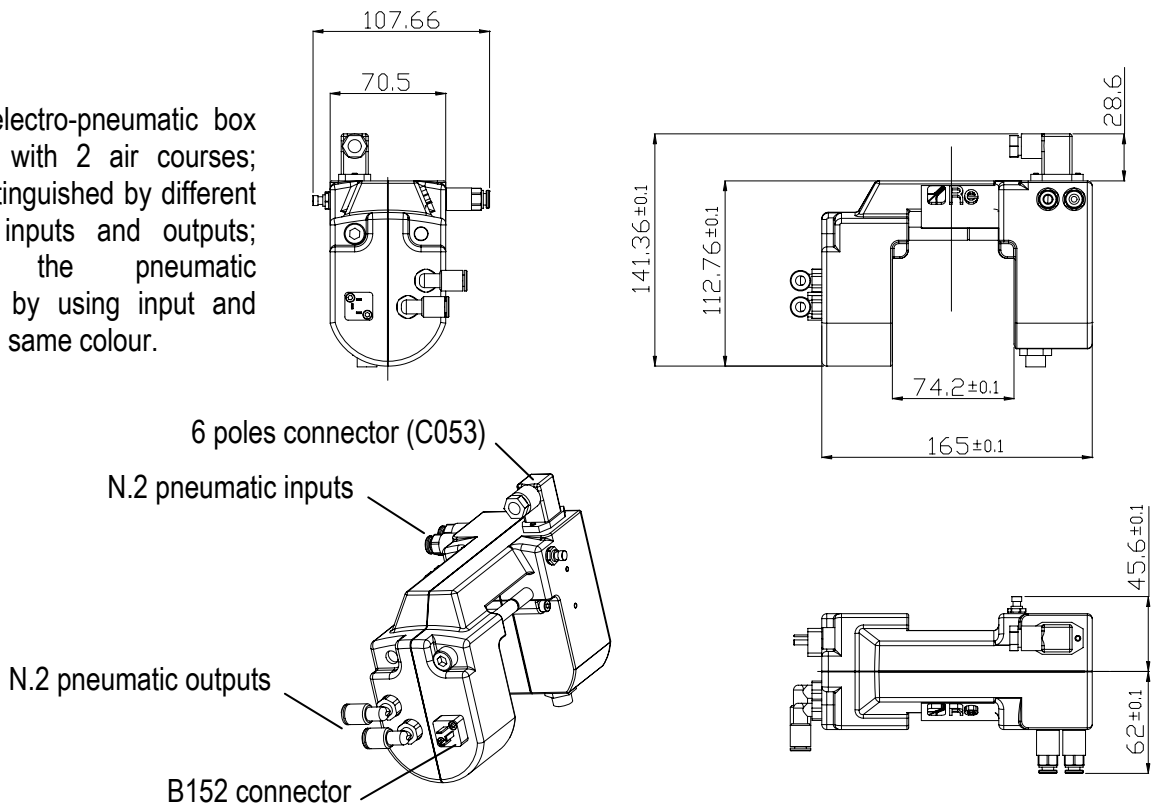

6 poles connector linkage diagram - CX.300

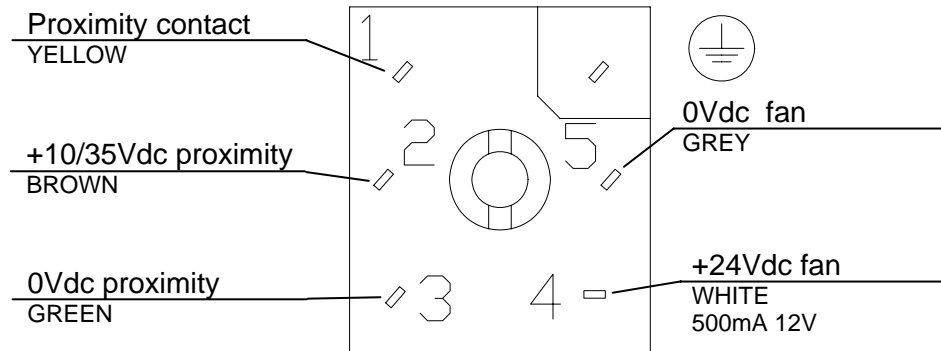

CX.400 brake

Assembly - CX.400

8 fixing holes, for M10 screw

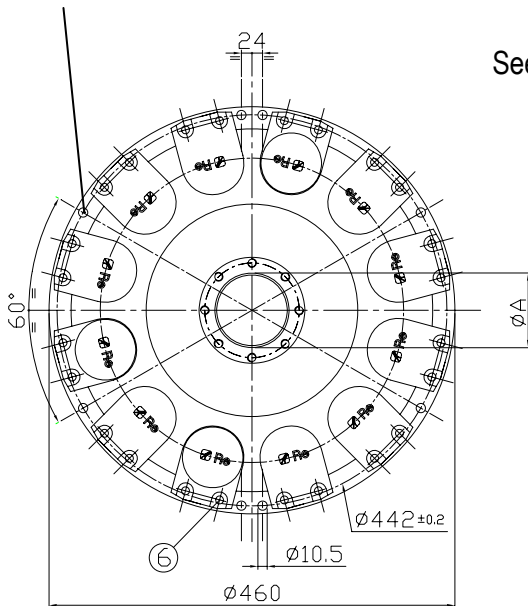

View from A

See detail of taper lock application

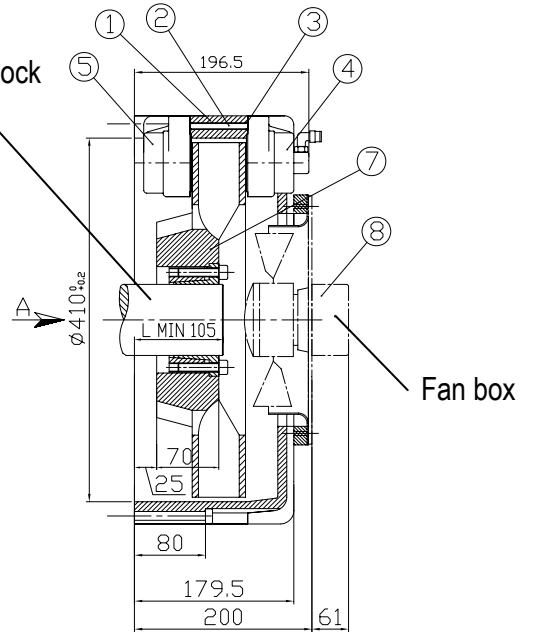

Dimension $\varnothing A$ subject to change: Min. 35mm - Max. 150mm with key
 With taper lock, shaft \varnothing max. 110mm

Detail of taper lock application

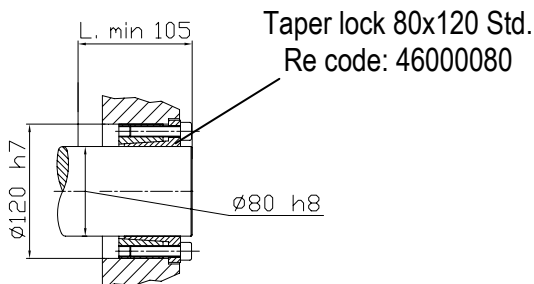

POS.	Q.TY	CODE	DESCRIPTION
1	2	4400210	CX400 HALF HOUSING
2	12	4409100 1	CX400/500 AIR TUBE
3	24	20000416	O-RING 6BIS VITON
4	X	4253100	OUTSIDE CALIPER
5	X	4253200	INSIDE CALIPER
6	24	10001035	SREW 8x110 UNI593 1
7	1	4404712	BRAKE DISC
8	1	80000004	CX400 FAN 220V

Turbine disc - CX.400

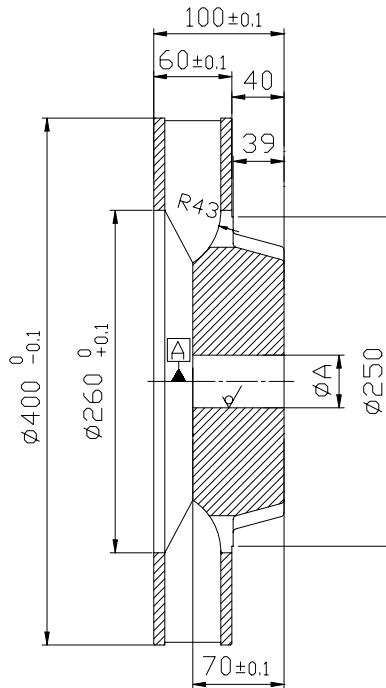

Dimension ØA subject to change on the basis of the customers requests: Min. 35mm - Max. 150mm with key
 With taper lock, max, shaft Ø 110mm

Fans connection diagrams - CX.400

24V fan for CX.400 brake (code M0401004)

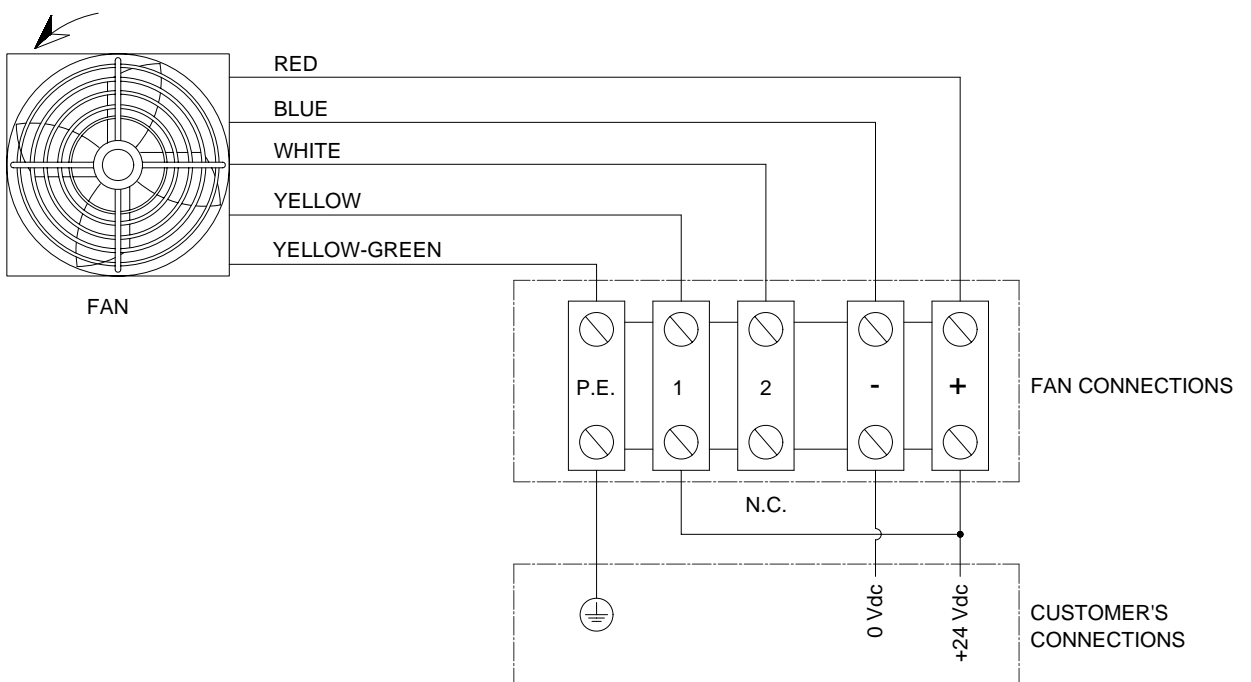

115V fan for CX.400 brake (code 8000003)

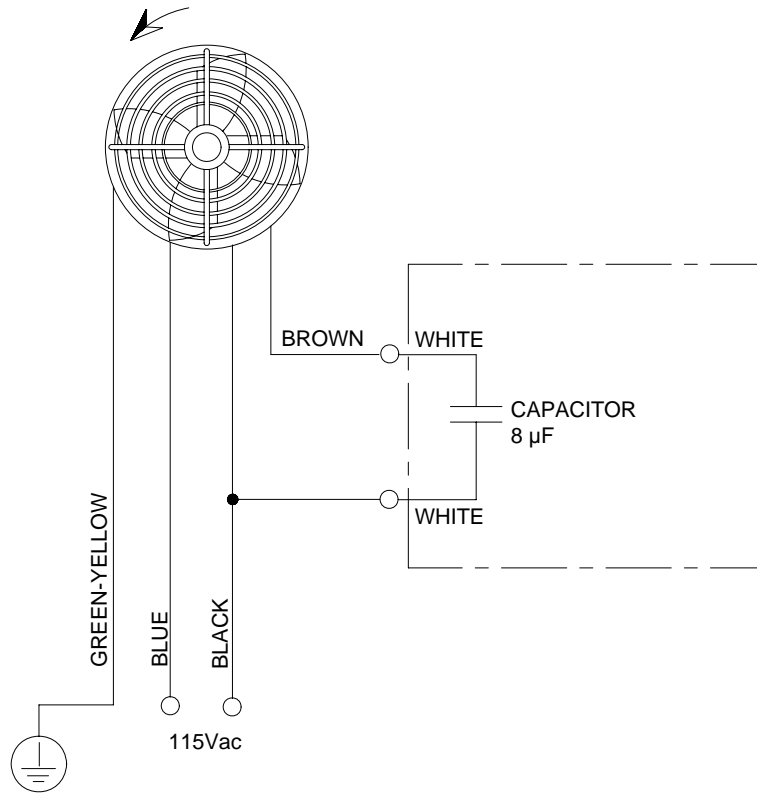

220V fan for CX.400 brake (code 8000004)

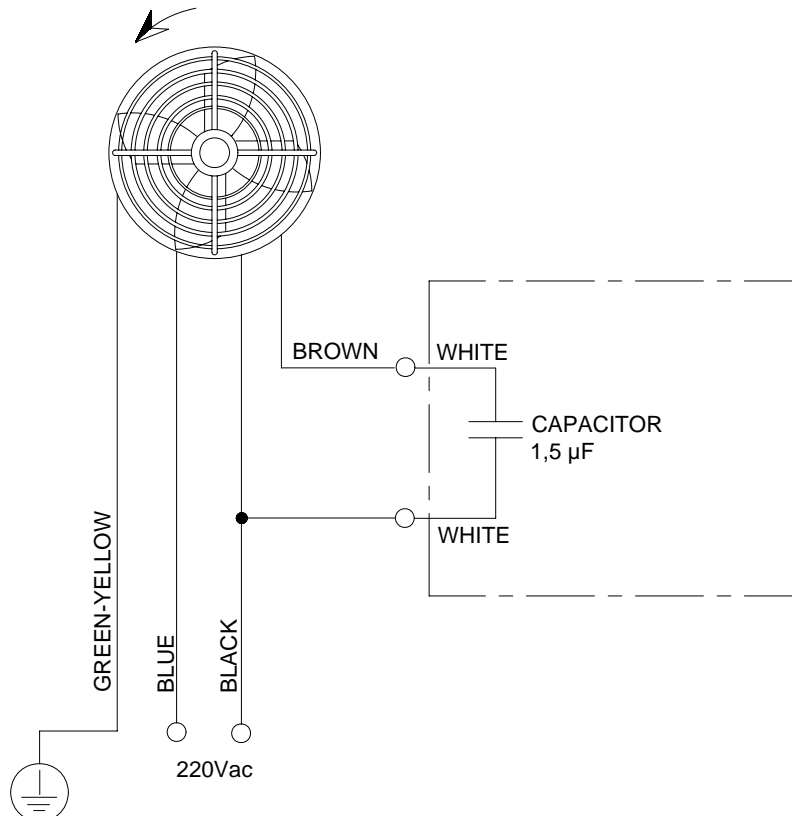

CX.500 brake

Assembly - CX.500

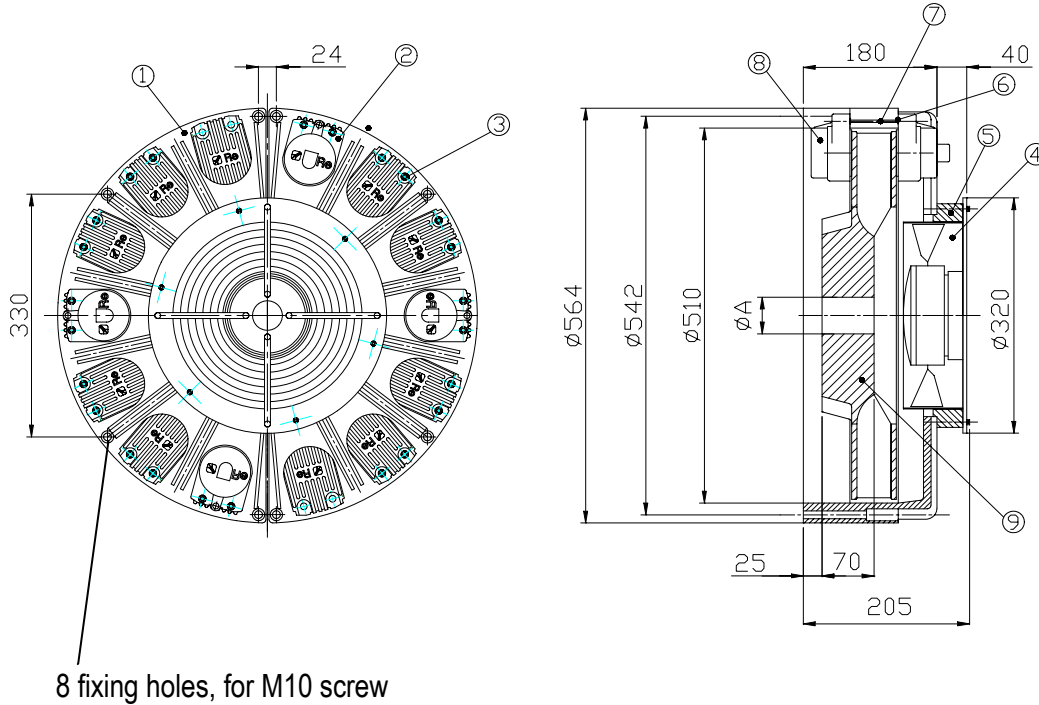

Dimension ØA subject to change: Min. 35mm - Max. 160mm with key
 With taper lock, max. shaft Ø 120mm

POS.	Q.TY	CODE	DESCRIPTION
1	2	4500210	CX500 HALF HOUSING
2	X	4253100	OUTSIDE CALIPER
3	16	10001094	SCREW 8x100 UNI 5931
4	1	80000010	FAN DIM 250 V115.60
4	1	80000011	FAN DIM 250 V220.50
5	1	4503410	CX500 FAN DISC
6	28	20000416	O-RING 6BIS VITON
7	14	44091001	CX400/500 AIR TUBE
8	X	4253200	INSIDE CALIPER
9	1	4504717	MACHINED BRAKE DISC

115V fan for CX.500 brake (code 80000010)

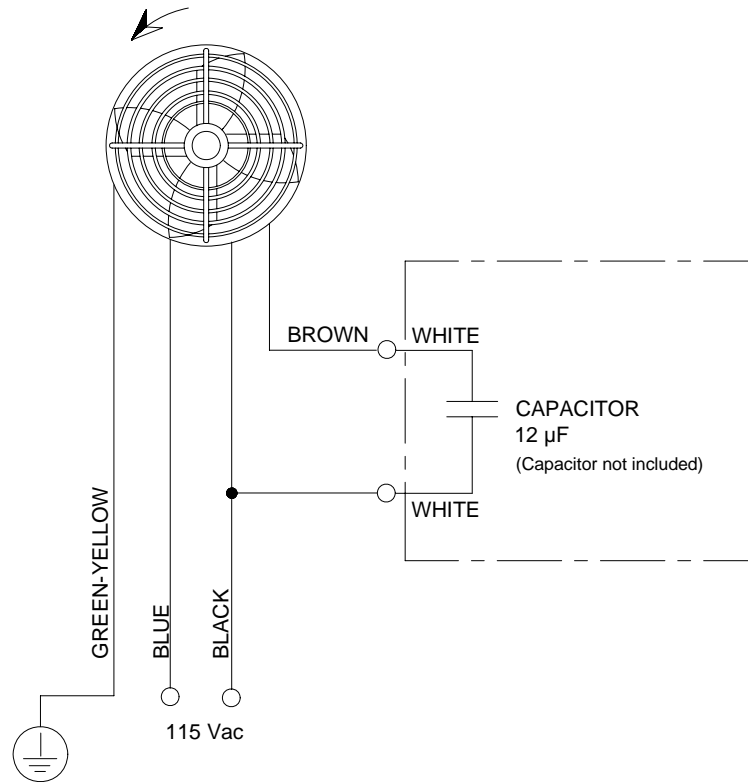

220V fan for CX.500 brake (code 80000011)

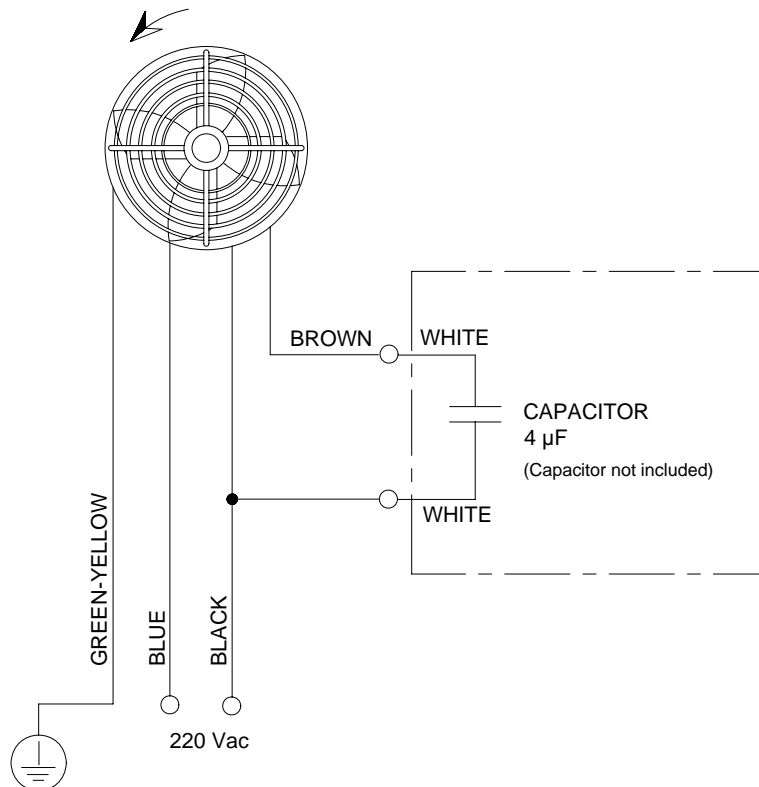

Fans for CX brakes - technical data

➤ Fans for **CX200**, **CX250 COMPACT** and **CX250 MINI** brakes

Type	Voltage	Frequency Hz	Air volume m ³ /h	Power input W	Noise level		Temperature range °C
					dBA	bels	
3314	24Vdc		80	2,6	37	5,2	-20... +75
3606	115V	60	89	11	42	5,2	-40... +75
3650	230V	50	75	12	36	4,8	-10... +55

➤ **115V** and **230V** fans for **CX250**, **CX251** and **CX300** brakes

Type	Voltage V	Frequency Hz	Air volume m ³ /h	Speed min ⁻¹	Power input W	Noise level dBA	Admiss. amb. temp. °C	Approx. weight kg
W2S 130-AA 03-01	230	50 - 60	325 - 380	2.800 - 3.250	45 - 39	49 - 53	50 - 70	1,2

➤ **24Vdc** fans for **CX250**, **CX251** and **CX300** brakes

Type	Voltage Vdc	Voltage range Vdc	Air volume		Speed min ⁻¹	Power input W	Noise level		Temperat. range °C	Service life L ₁₀	
			m ³ /h	CFM			dBA	bels		at 40°C Hours	at t _{max} Hours
	7114N	24	12 ... 30	360	211,9	2.850	12	55	6,5	-25... +72	80.000

➤ **115V** and **220V** fans for **CX400** brakes

Type	Voltage V	Frequency Hz	Air volume m ³ /h	Speed min ⁻¹	Power input W	Current consumpt. A	Capacitor µF	Noise level dBA	Electrical design BR.Nr	Admiss. amb. temp. °C
. 2E 200	220	50 - 60	790 - 885	2.650 - 3.000	58 - 70	0,27 - 0,33	2 - 1,5	64 - 69	152	75 - 75

➤ **115V** and **220V** fans for **CX500** brakes

Type	Voltage V	Frequency Hz	Air volume m ³ /h	Speed min ⁻¹	Power input W	Current consumpt. A	Capacitor µF	Noise level dBA	Electrical design BR.Nr	Admiss. amb. temp. °C
. 2E 250	220	50 - 60	1.670	2.500	135	0,62	4	69	4	55 - 55

➤ **24Vdc** fans for **CX400** and **CX500** brakes

Type	Voltage Vdc	Voltage range Vdc	Air volume		Speed min ⁻¹	Power input W	Noise level dBA	Temperat. range °C	Service life L ₁₀	
			m ³ /h	CFM					at 40°C Hours	at t _{max} Hours
	W1G 200-HH77-52	24	16 ... 28	1090	641,6	2.950	55	60	-15... +60	55.000

CX half caliper - internal side

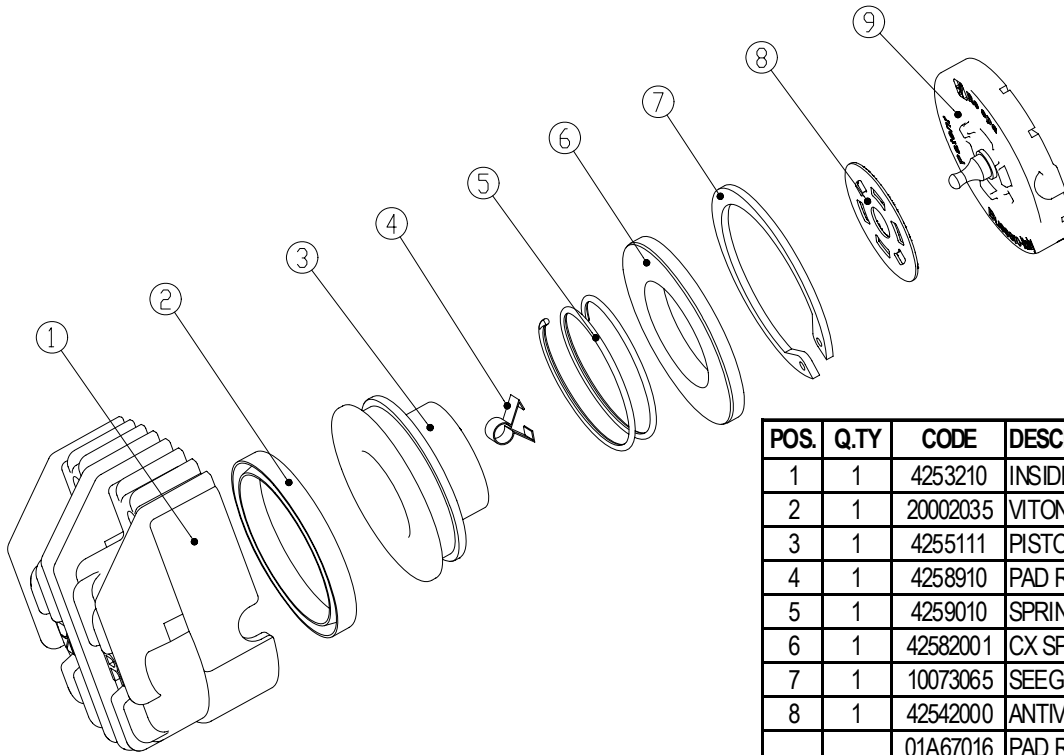

POS.	Q.TY	CODE	DESCRIPTION
1	1	4253210	INSIDE CALIPER
2	1	20002035	VITON LIP SEAL
3	1	4255111	PISTON
4	1	4258910	PAD RETAINING SPRING
5	1	4259010	SPRING
6	1	42582001	CX SPRING RETAINING RING
7	1	10073065	SEEGER 65 UNI 7437-75 I.
8	1	42542000	ANTIVIBRATION RING
9	1	01A67016	PAD R15
		4254209	PAD NT
		4254220	PAD KEVLAR

CX half caliper - external side

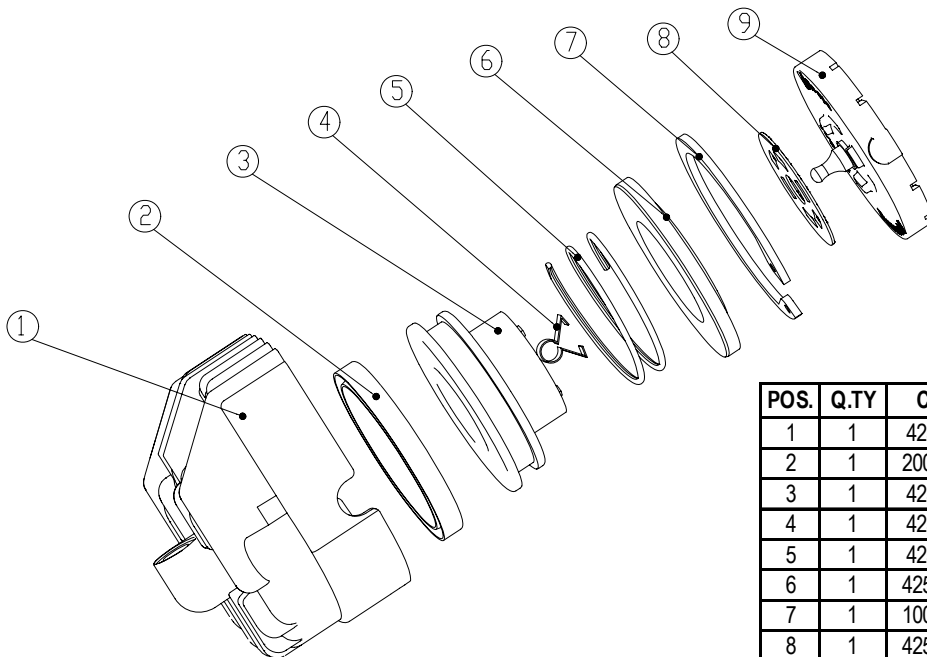

POS.	Q.TY	CODE	DESCRIPTION
1	1	4253112	OUTSIDE CALIPER
2	1	20002035	VITON LIP SEAL
3	1	4255111	PISTON
4	1	4258910	PAD RETAINING SPRING
5	1	4259010	SPRING
6	1	42582001	CX SPRING RETAINING RING
7	1	10073065	SEEGER 65 UNI 7437-75 I.
8	1	42542000	ANTIVIBRATION RING
9	1	01A67016	PAD R15
		4254209	PAD NT
		4254220	PAD KEVLAR

Reduced calipers

It is possible to mount calipers with reduced braking power on the CX brakes. Using reduced callipers makes it possible to have more accurate tension control for many applications that do not demand the brake's maximum torque.

CALIPER COLOUR	BRAKING FACTOR
Yellow	10%
Blue	16%
Red	40%

Example:

If you supply pneumatically a CX250 brake at the maximum pressure (6 bar), the braking torque value of the **standard** caliper (black) is **16 DaNm**.

Instead, using the reduced calipers in the same conditions, the braking torque values are lower:

- reduced caliper **10%** (yellow): braking torque **1,6 DaNm**
- reduced caliper **16%** (blue): braking torque **2,56 DaNm**
- reduced caliper **40%** (red): braking torque **6,4 DaNm**

Pads

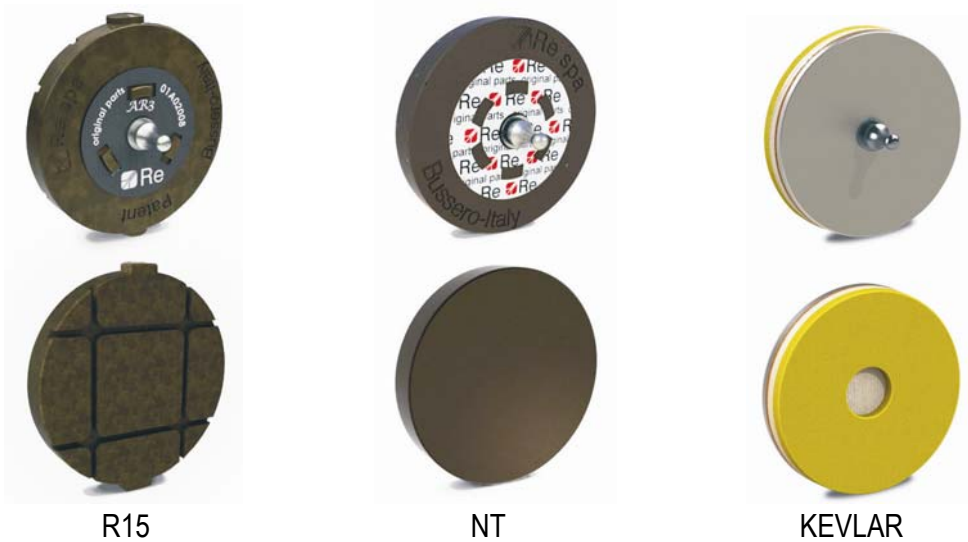

The brake pad choice is extremely important for the brake to continue working efficiently and to obtain the expected performance from the brake. Temperature, torque and speed are all variables that place very high stress on brake pads. Our technicians reproduced these variables during performance tests. This non-stop research and the evolution of available materials allowed us to develop many different products: from the more common and inexpensive pads, while always maintaining the required torque, to more innovative pads that allow you to work at high temperatures while keeping an above average lifespan and reducing your maintenance time.

We have not neglected environmental issues. Our pads produce very low powder. We reached a 70% under standard powder production, while keeping brake performance as high as standard.

Contact our technical-sales office to receive more information about how we can best meet your needs for pads and pneumatic brakes.

	R15	NT	KEVLAR
Asbestos free	YES	YES	YES
Powder emission limitation	●●●●	●●●●	●●
High temperature behaviour	●●●●	●●●●	●●
Lifespan	●●●●	●●	●●●● *
Waterproof	●●●●	●●	●●
RoHS compliance	YES	YES	YES
Antivibration	●●● (AR3)	●● (AR1)	NO
Antirotation	YES	NO	NO

●● fairly good ●●● good ●●●● very good ●●●●● excellent

* pad lifespan is shortened if you use standard discs

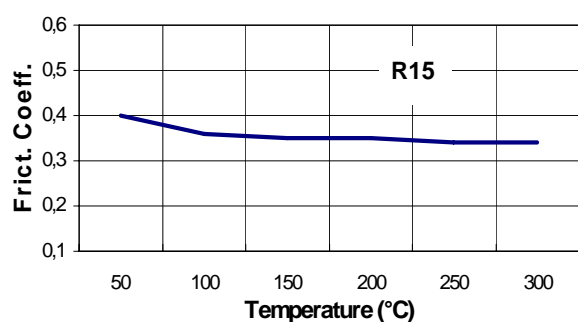
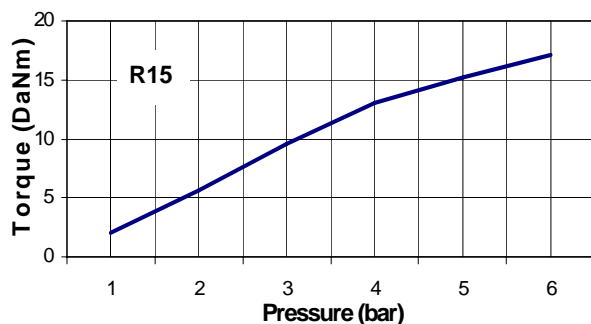

Guarantee

Re S.p.A. guarantees this device against all defects relative to the materials and manufacturing for a period of 12 months from the date of delivery.

Should your device develop operating faults during the guarantee period, please contact the Company's agent in your country, or, if this is not possible, contact Re S.p.A. directly.

The guarantee includes spare parts and labour. It does not include shipment costs for device delivery or recall.

The guarantee is invalidated by:

- improper use of the device
- incorrect installation
- lack of maintenance
- changes or work involving non-original components or carried out by persons without Re S.p.A. authorisation
- complete or partial failure to observe the instructions
- exceptional events.

At the end of the guarantee period, support will be provided by the support network, which will carry out repairs at the current rates.

Re S.p.A. Controlli Industriali

Via Firenze, 3 - 20060 BUSSERO (MI) ITALY

Fax (+39) 02 95 03 89 86

Technical support:

Tel. (+39) 02 95 24 30.300 - E-mail: support@re-spa.com

Sales support:

Tel. (+39) 02 95 24 30.200 - E-mail: sales@re-spa.com

www.re-spa.com

Rev. 12/11